

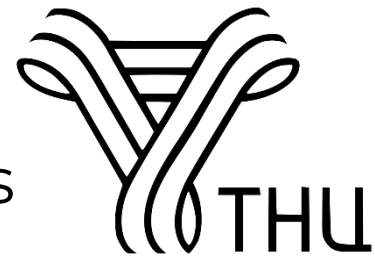

7th International Congress on
Energy Fluxes and Radiation Effects



**NUMERICAL SIMULATION OF COMBUSTION PROCESS
IN ROTARY RANGE EXTENDER
WITH HYDROGEN DIRECT MULTIPLE INJECTION**

Zambalov S.D.

Department of Structural Macrokinetics of Tomsk Scientific Center of SB RAS

World emissions

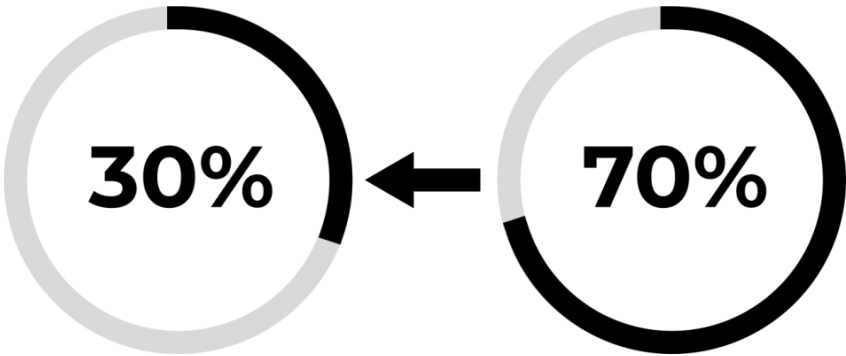

International Energy Agency



Battery electric vehicle

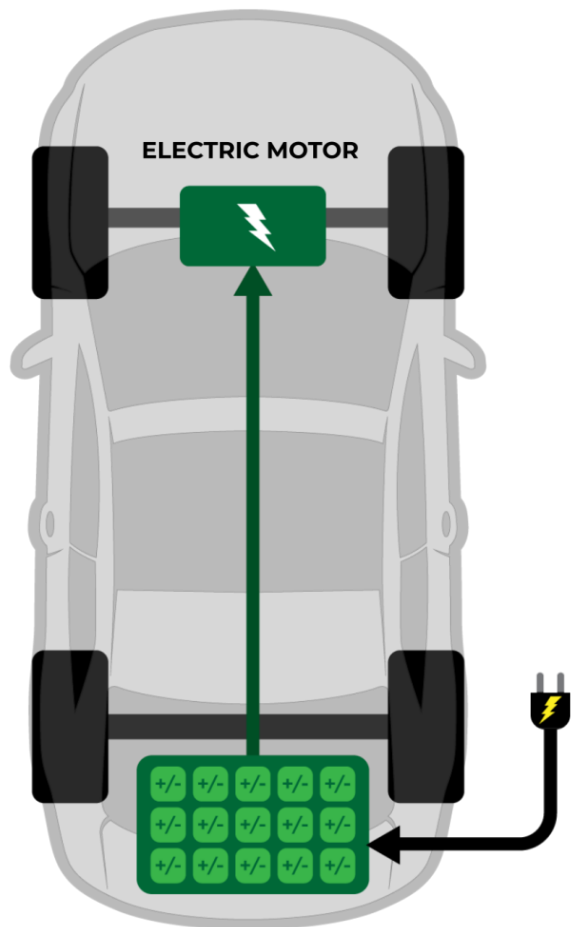

RECHARGEABLE BATTERY PACK

Extended range battery electric vehicle

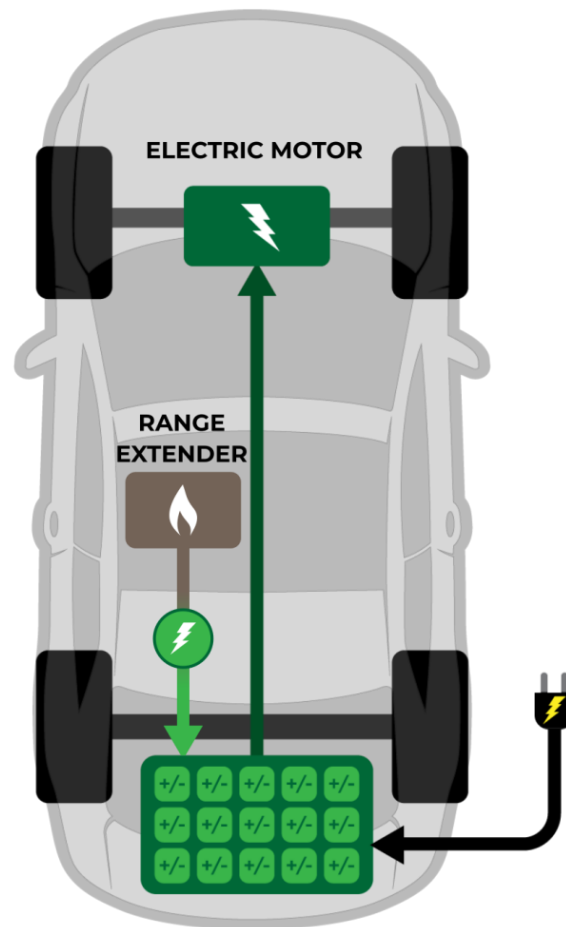

RECHARGEABLE BATTERY PACK

Range extender engine types

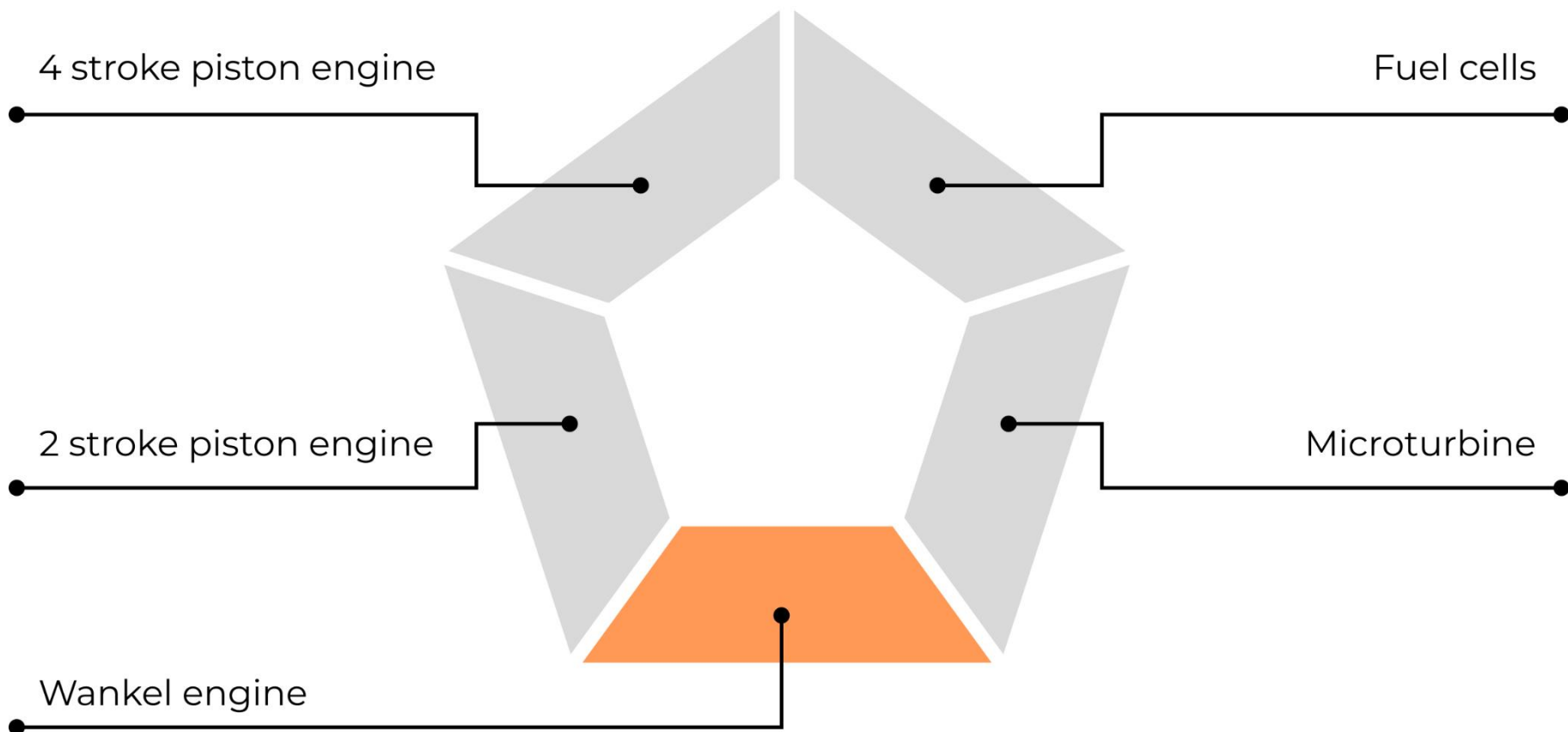

Wankel engine

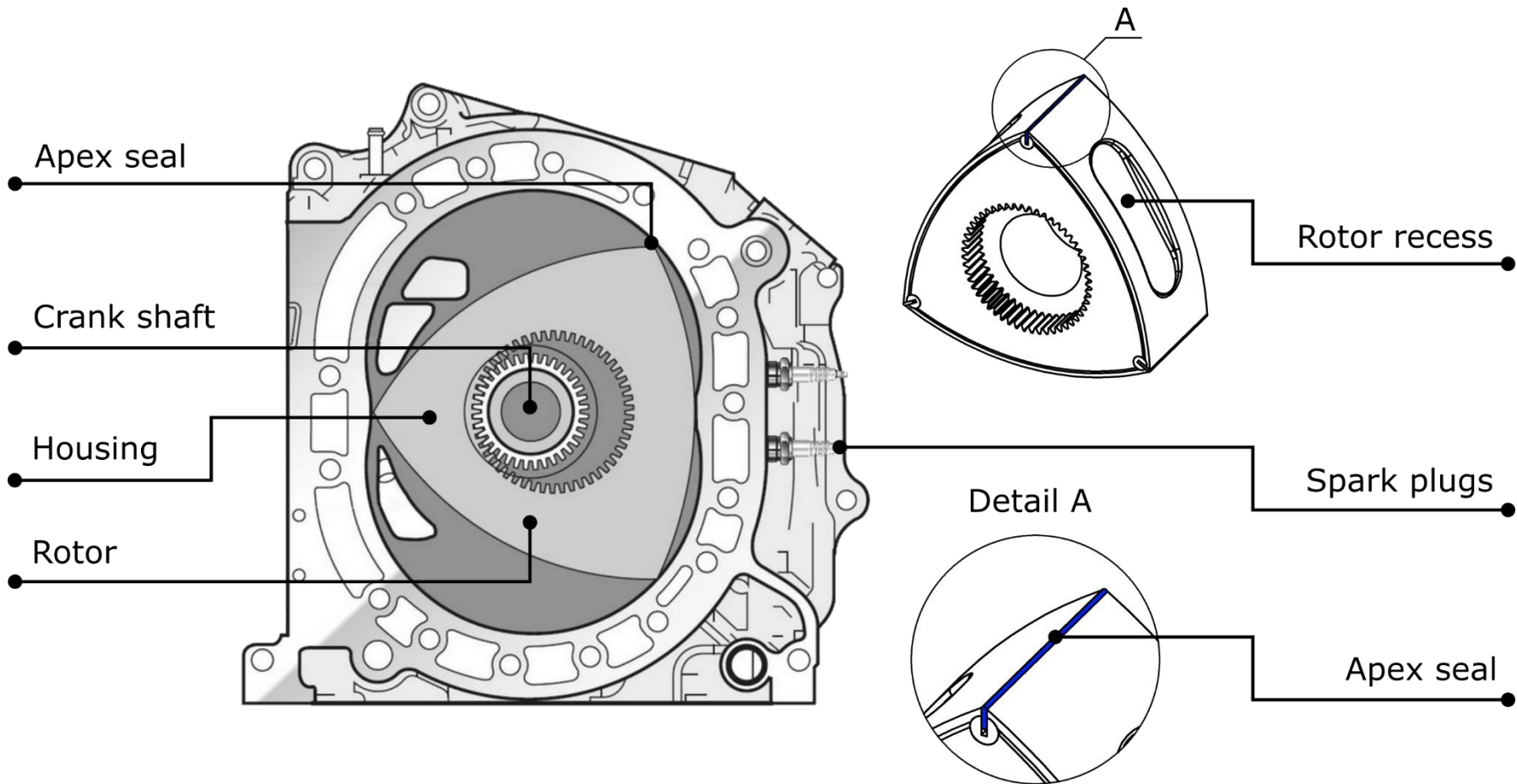

Scheme of engine

Technical specifications

Displacement	250 cc
Generating radius	84 mm
Eccentricity	11 mm
Width	52 mm
Compression ratio	10
Intake port open	3 CA ATDC
Intake port close	60 CA ABDC
Exhaust port open	40 CA BBDC
Exhaust port close	3 CA BTDC
Injection start	210 CA BTDC
End of injection	90 CA BTDC
Leading spark plug	35 CA BTDC
Trailing spark plug	25 CA BTDC

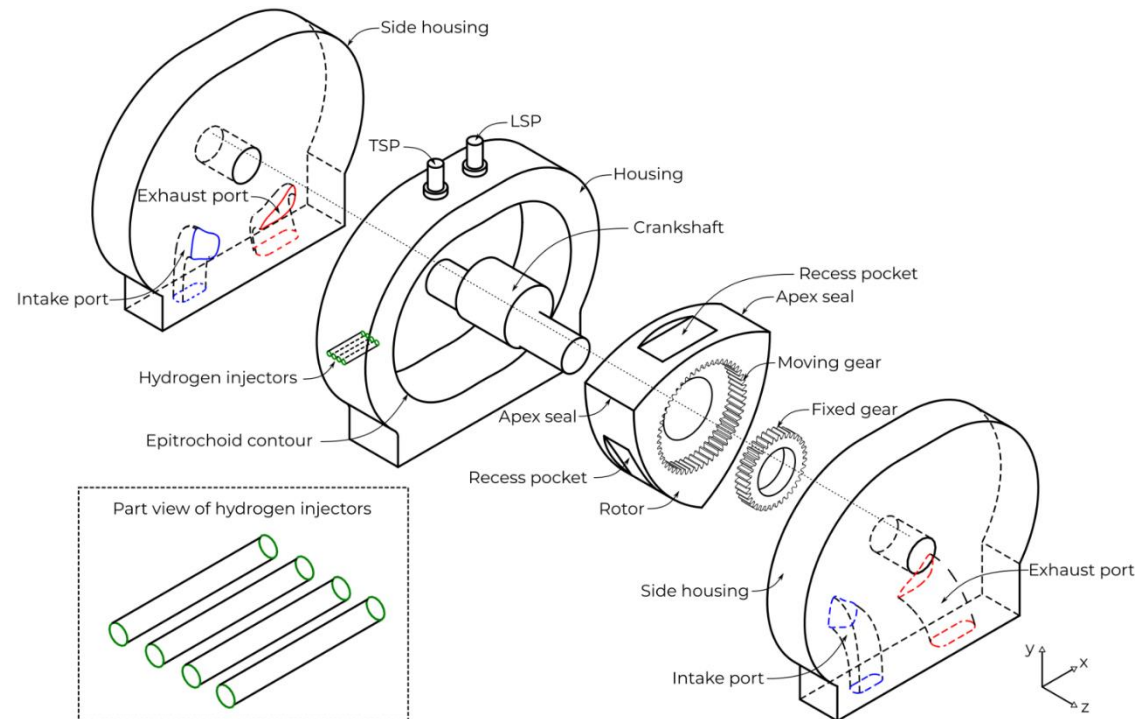

Multiple injection types

Case A

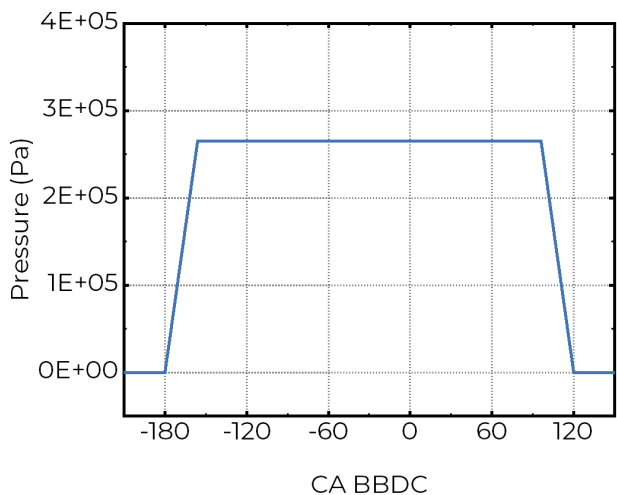

Case B

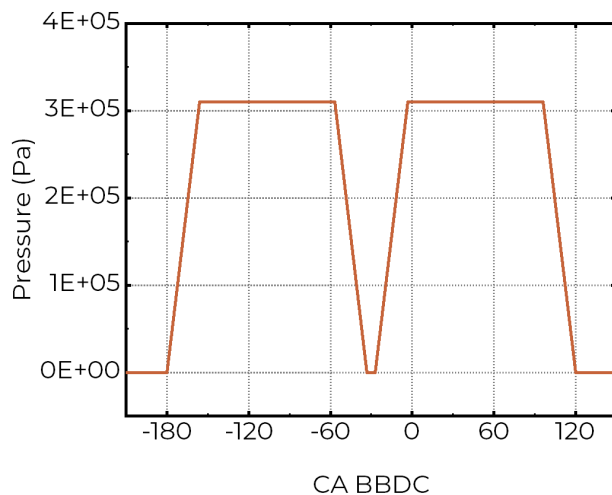

Case C

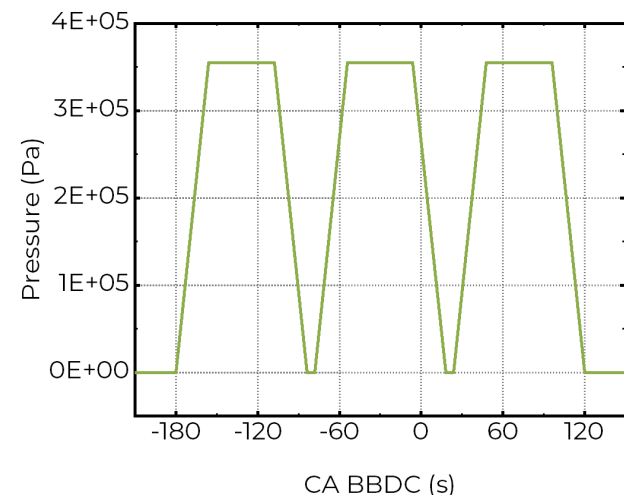

Induction stroke

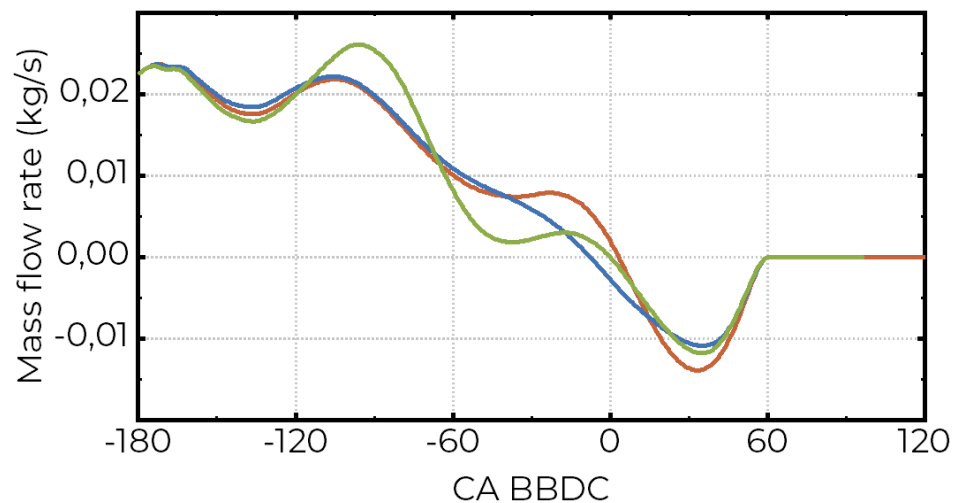
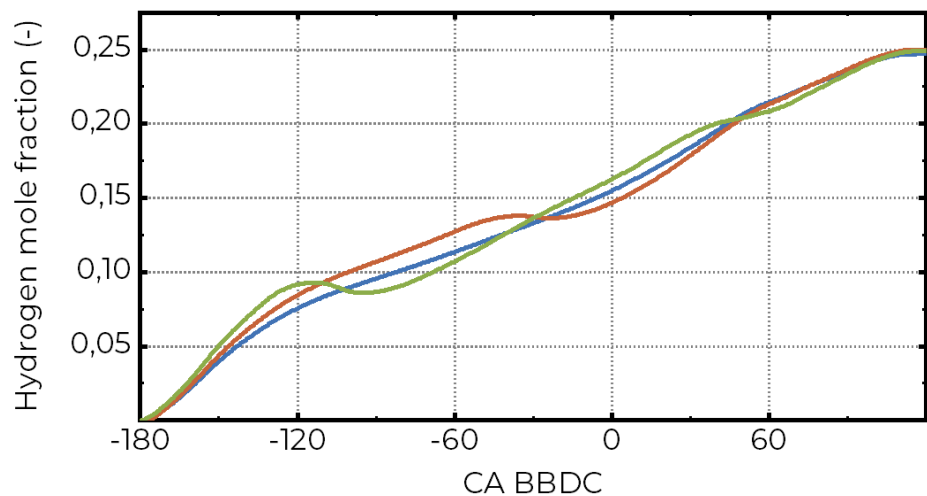

Case A

Case B

Case C

Combustion stroke

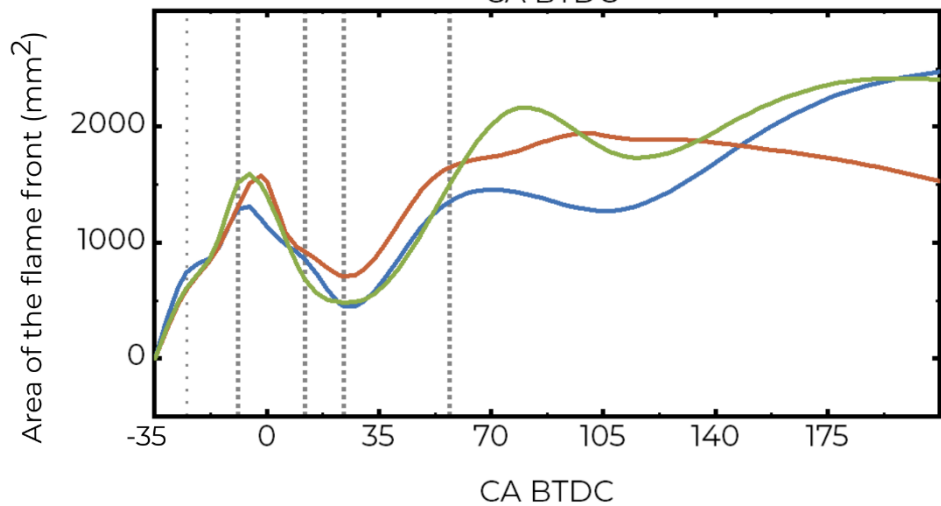
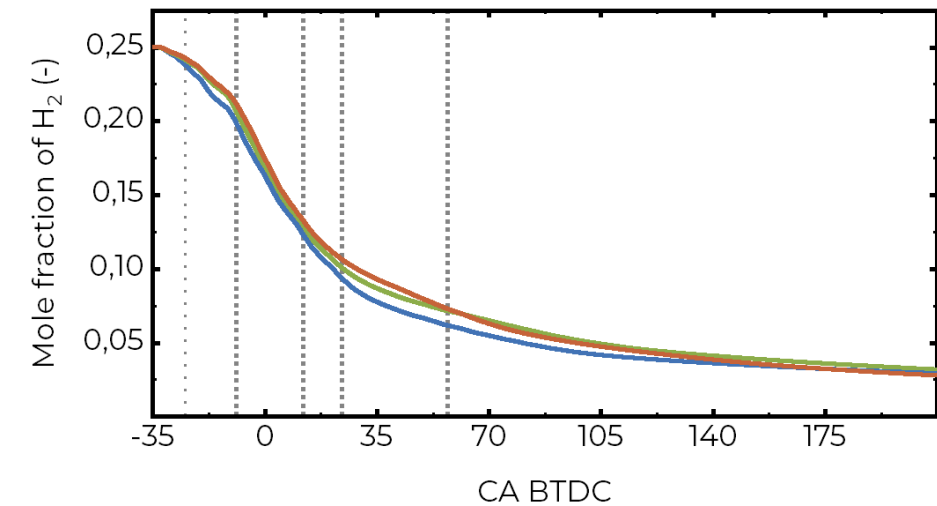
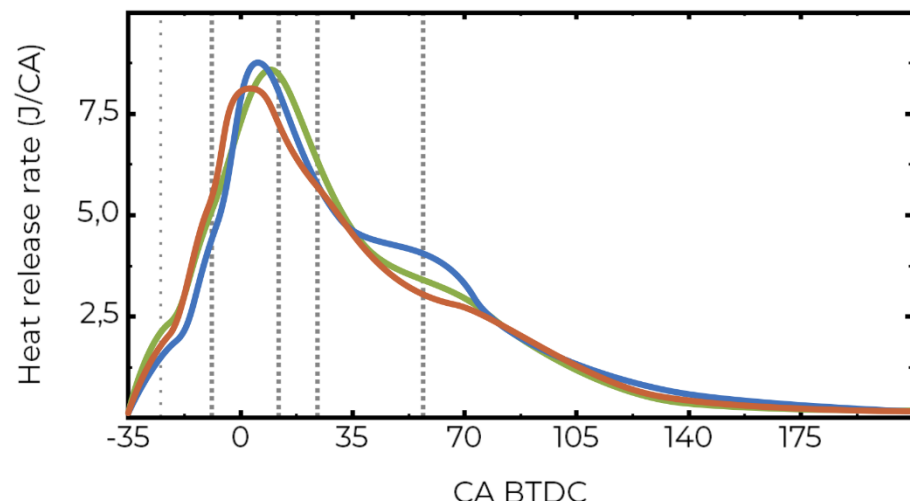
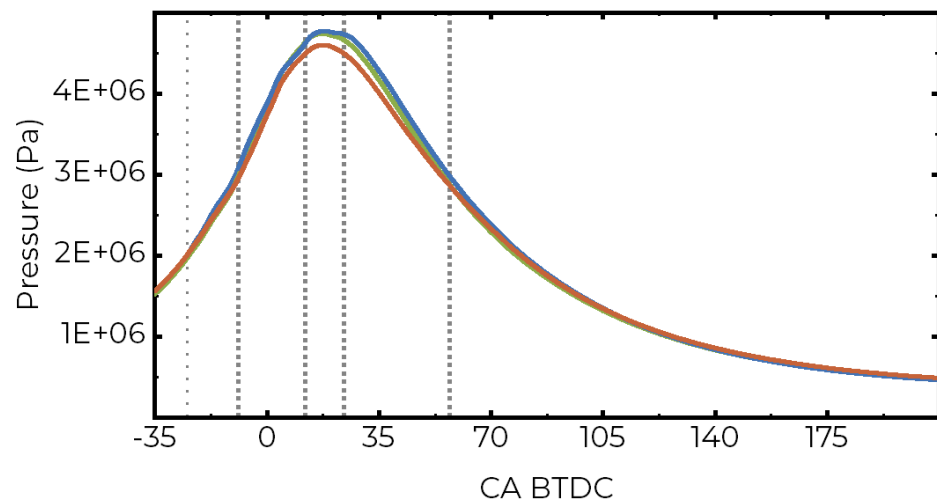

7th International Congress on Energy Fluxes and Radiation Effects

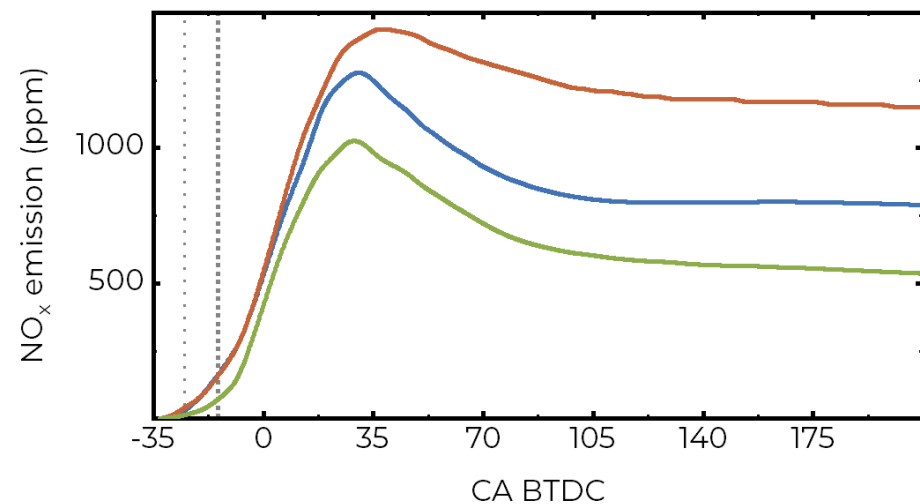
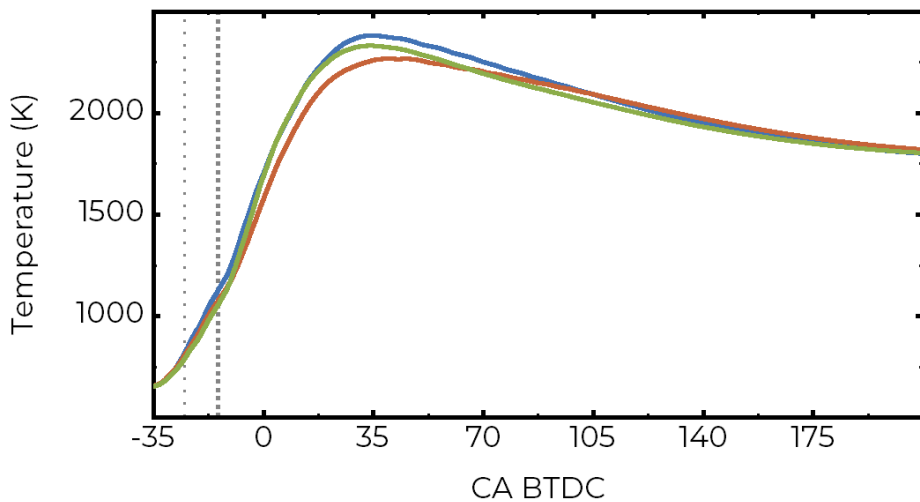
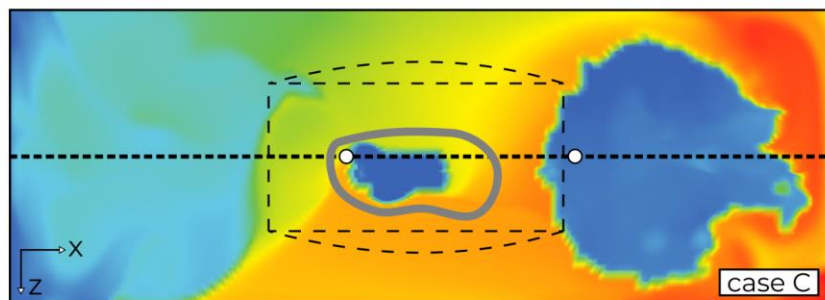
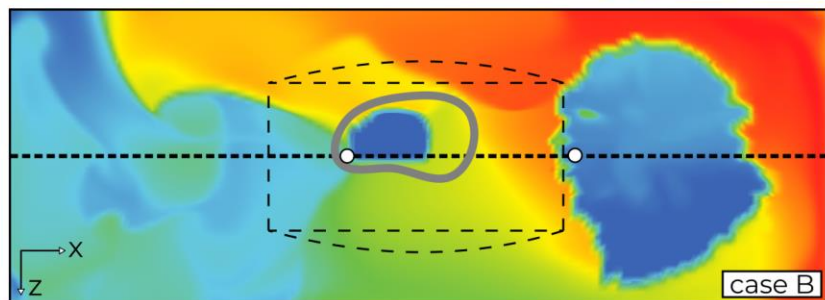
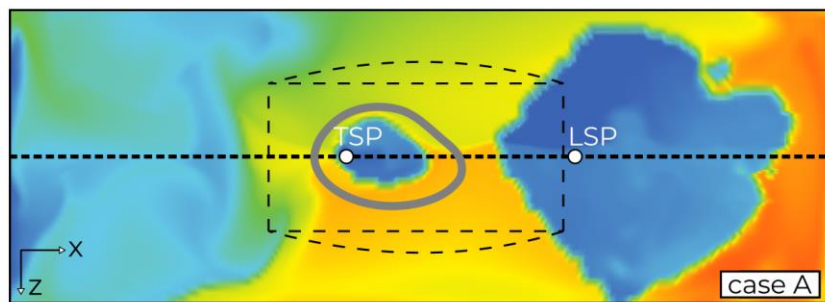

7th International Congress on Energy Fluxes and Radiation Effects

Performance parameters

Case	Indicated mean effective pressure, kPa	Indicated power, kW	Thermal conversion efficiency	NO _x emission, ppm
A	987	20.5	0.36	781
B	965	20.1	0.34	1130
C	965	20.1	0.35	526

Range extender prototypes comparison

Company	Type	Displacement, cc	Power, kW	Power per unit volume, kW/cc
Lotus engineering	Piston engine, 3 cyl, Gasoline	1200	36.8	0.03
Mahle Powertrain	Piston engine, 2 cyl, Gasoline	900	30	0.03
Mazda Motor	Rotary engine, 1 section, Gasoline	330	22	0.06
University of Toronto	Rotary engine, 1 section, Hydrogen	654	13.8	0.02
Tomsk Scientific Center	Rotary engine, 1 section, Hydrogen	250	20.5	0.08

Thank you for your attention!